

# Technician's Service Guide

---

AWBTSG0001-1

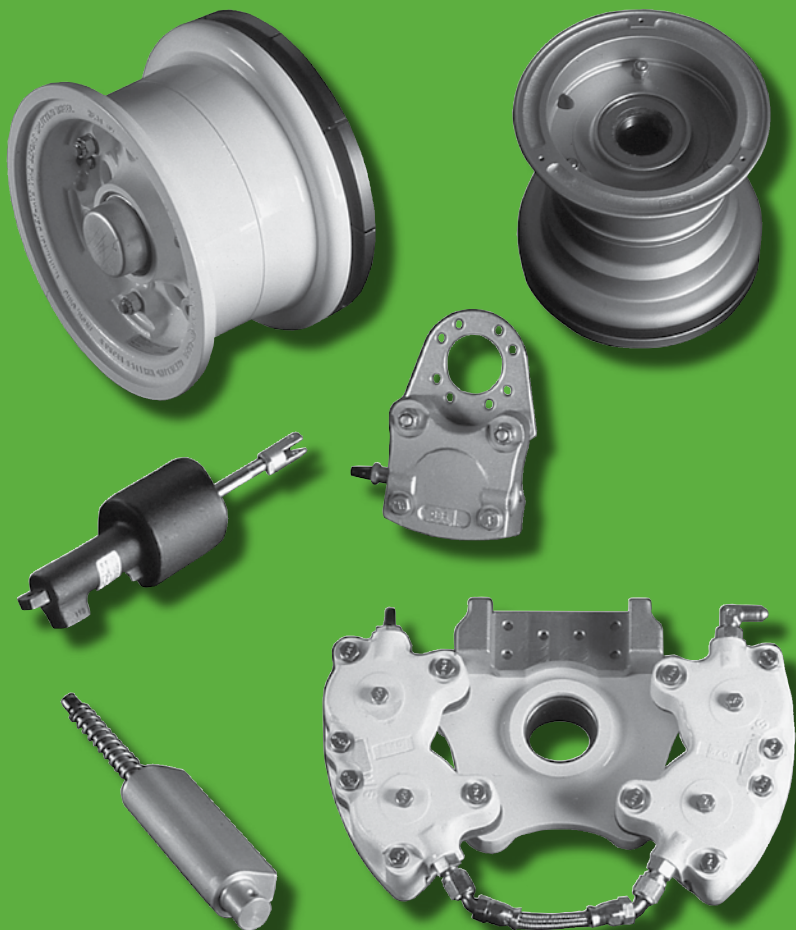

**Cleveland**  
Wheels & Brakes



## Reference

Publication Number: **AWBTSG0001-1/USA**  
Issue 1, Dated: **May 15, 2006**

© Copyright 2006 and years of revision, Parker Hannifin Corporation  
All rights reserved.

---

## WARRANTY

The warranty clause for the wheel and brake commercial product line is found on the inside back cover of the current Cleveland Wheels & Brakes Price List.

## IMPORTANT NOTE

Use of other manufacturer's components with original Cleveland wheel and brake assemblies will void the Cleveland Wheels & Brakes warranty.

---

## TECHNICAL ASSISTANCE

For technical questions and assistance, contact the Cleveland Wheels & Brakes Technical Support Team:

**TECHNICAL SERVICES HOTLINE:**

[techhelp@parker.com](mailto:techhelp@parker.com)

Fax: 440-937-5409

1-800-BRAKING (272-5464) Tel.: 440-937-1315

# Reference

## MANUAL USAGE

The procedures in this technician's guide are applicable to external design wheels and brakes only.

Refer to the Component Maintenance Manual for detailed maintenance/overhaul procedures. Refer to the Product Catalog for Illustrated Parts Breakdown. Consult the Aircraft Maintenance Manual and Airframe Log Books (for optional installations) to confirm the approved part numbers for the particular aircraft application. If any inconsistencies are observed in this data, please notify Cleveland Wheels & Brakes Customer Support.

---

## MANUAL UPDATES

Effective May 15, 2006, this publication is now identified as the Technician's Service Guide under the document number "AWBTSG0001-x", which is located in the upper left corner of each page. The "-x" suffix indicates the manual issue number, where "-1" is the first issue. AWBTSG0001-1 (dated May 15, 2006) supersedes PRM64 Revision J (dated January 1, 2005).

Whenever an interim revision to the publication is required the information will be listed on the Record of Temporary Revisions page, which precedes the Table of Contents page. The Temporary Publication Notice (TPN) provides detailed revision information to selective sections of the parent publication. Each TPN is identified with the parent publication number and a sequentially assigned revision number indicating the revision level of the parent publication it has been issued against.

For example: TPN\_AWBTSG0001-1.1 is the first interim revision issued against AWBTSG0001-1. TPN\_AWBTSG0001-1.2 would be the second interim revision and so forth. Whenever a general revision of the parent document is required, the publication's revision number is advanced and the TPN process will begin again.

Consult the Cleveland Wheels & Brakes website for current service publications and any TPN's that have been issued against it. For additional information regarding publication availability please contact the Cleveland Wheels & Brakes Technical Support Team.

# Record of Temporary Revisions

REVISION	DESCRIPTION OF CHANGE	DATE
AWBTSG0001-1.1	Refer to Technical Publication Notice TPN_AWBTSG0001-1.1	07-01-2007

# Table of Contents

This manual has been created to assist the maintenance technician on the shop floor.

TOPIC	PAGE
A. Conditioning Procedures.....	2
B. Brake Lining Wear Limits .....	3
C. Brake Disc Minimum Thickness .....	4-5
D. Chrome/Performance Gold Disc Maintenance.....	6
E. Brake Assembly/Lining Cross-Reference.....	6-8
F. Wheel Assembly Torque Values .....	9-13
G. Tire Inflation Valve Stem Torque.....	13
H. Back Plate Tie Bolt Torque .....	14-17
I. Special Tools .....	18
J. Elastomeric Compound Lubricants.....	18
K. Lubricants .....	18
L. Repair Materials.....	19
M. Primers and Paints.....	19
N. Chemical Stripping Agents.....	19

# A. Conditioning Procedures

When new linings have been installed, it is important to condition them properly to obtain the service life designed into them. The metallic and organic operating characteristics. Separate conditioning procedures are given for metallic and organic linings.

NON-ASBESTOS ORGANIC LININGS	METALLIC LININGS
<ol style="list-style-type: none"> <li>1. Taxi aircraft for 1500 feet with engine at 1700 rpm applying brake pedal force as needed to develop a 5-10 mph taxi speed.</li> <li>2. Allow the brakes to cool for 10 to 15 minutes.</li> <li>3. Apply brakes and check for restraint at high static throttle. If brakes hold, conditioning is complete.</li> <li>4. If brakes cannot hold aircraft during static run-up, allow brakes to completely cool and repeat steps 1 through 3.</li> </ol>	<ol style="list-style-type: none"> <li>1. Perform two (2) consecutive full stop braking applications from 30 to 35 knots. Do not allow the brake discs to cool substantially between the stops.</li> <li>2. Allow the brakes to cool for 10 to 15 minutes.</li> <li>3. Apply brakes and check for restraint at high static throttle. If brakes hold, conditioning is complete.</li> <li>4. If brakes cannot hold aircraft during static run-up, allow brakes to cool completely and repeat steps 1 through 3.</li> </ol>

**CAUTION: DUE TO THE EFFICIENCY OF THESE BRAKES, EXTREMELY HARD BRAKING ON AIRCRAFT WITH TAIL WHEELS COULD RESULT IN LIFTING THE TAIL FROM THE GROUND.**

These conditioning procedures will wear off high spots and generate sufficient heat to create a thin layer of glazed material at the lining friction surface. Normal brake usage should generate enough heat to maintain the glaze throughout the life of the lining.

Properly conditioned linings will provide many hours of maintenance free service. A visual inspection of the brake disc will indicate the lining condition. A smooth surface, one without grooves, indicates the linings are properly glazed. If the disc is rough (grooved), the linings must be reglazed. The conditioning procedure should be performed whenever the rough disc condition is observed. Light use, such as in taxiing, will cause the glaze to be worn rapidly.

## B. Brake Lining Wear Limits

The minimum replacement thickness on metallic and organic linings is 0.100 inch (2.54 mm). Refer to Figure A1.

**NOTE:** On some designs the metallic lining is bonded directly to the pressure plate and back plate. In these cases, the part should be replaced when the lining material is worn to 0.030 inch (0.76 mm) thick.

For equipment used on Piper Aztec (using either 164-00206 or 164-03206 disc), see PRM19 or follow the procedure below:

- First, measure linings as shown in Figure A1. Linings worn below .100 inch are cause for replacement.
- If linings are still usable or are replaced, measure the cumulative thickness of two linings, disc and pressure plate as shown in Figure A1-1. If the stack measures less than 1.00 (1 inch) with good linings (linings above .100 inch) the brake disc is considered below minimum wear thickness and should be replaced.

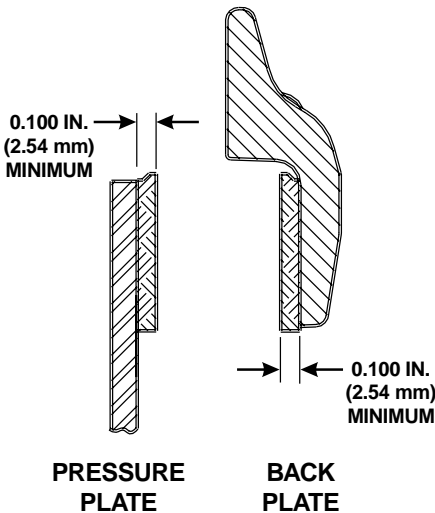

Figure A1  
Minimum Lining Thickness

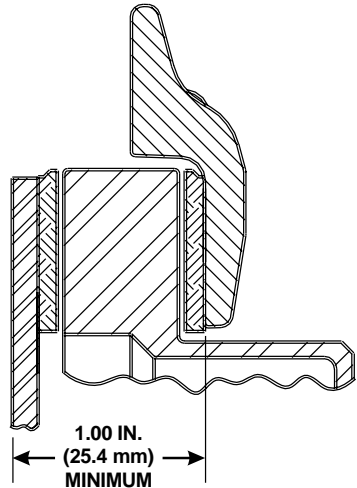

Figure A1-1  
Disc Wear Measurement  
(Piper Aztec)

## C. Brake Disc Minimum Thickness

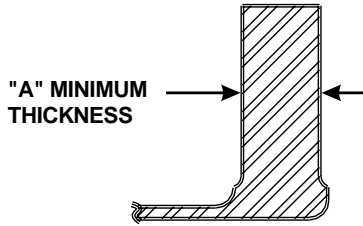

Figure A2 – Disc Thickness Measurement

Under average field conditions, a brake disc should give years of trouble free service. However, unimproved fields, standing water, heavy industrial pollution or infrequent use of the aircraft may necessitate more frequent inspection of discs to prolong the life of the brake lining.

Generally, the disc faces should be checked for wear (Figure A2 Dim. "A"), grooves, deep scratches, excessive general pitting or coning of the brake disc. Coning beyond 0.015 inch (0.381 mm) in either direction would be cause for replacement.

Single or isolated grooves up to 0.030 inch (0.76 mm) deep should not be cause for replacement, although general grooving of the disc faces will reduce lining life.

Discs are plated for special applications only; therefore, rust in varying degrees can occur. If a powder rust appears, one or two braking applications during taxi should wipe the disc clear. Rust allowed to progress beyond this point may require removal of the disc from wheel assembly to properly clean both faces. Wire brushing followed by sanding with 220 grit sandpaper can restore the braking surface for continued use.



# C. Brake Disc Minimum Thickness

Part Number	"A" in/mm
159-00104	0.225/5.715
159-00204	0.475/12.065
164-00206	See Page 3
164-00300	0.205/5.207
164-00400	0.162/4.115
164-00500	0.157/3.988
164-00700	0.345/8.763
164-00806	0.334/8.484
164-00900	0.227/5.766
164-01000	0.345/8.763
164-01100	0.345/8.763
164-01300	0.227/5.764
164-01406	0.334/8.484
164-01501	0.327/8.306
164-01506	0.327/8.306
164-01600	0.157/3.988
164-01700	0.167/4.242
164-01900	0.227/5.766
164-02000	0.205/5.207
164-02201	0.345/8.763
164-02300	0.345/8.763
164-02501	0.445/11.303
164-02502	0.445/11.303
164-02503	0.445/11.303
164-02504	0.445/11.303
164-02505	0.445/11.303
164-02601	0.205/5.207
164-02700	0.330/8.382
164-02701	0.340/8.636
164-02706	0.330/8.382
164-02707	0.330/8.382
164-02800	0.227/5.766
164-02900	0.580/14.732
164-03006	0.282/7.163
164-03106	0.163/4.140
164-03206	See Page 3
164-03300	0.235/5.969
164-03506	0.260/6.604
164-03600	0.327/8.306
164-03601	0.327/8.306
164-03700	0.345/8.763
164-03906	0.600/15.240
164-04000	0.205/5.207
164-04300	0.205/5.207
164-04406	0.334/8.484
164-04600	0.405/10.287
164-04700	0.345/8.763
164-04800	0.327/8.306
164-05006	0.475/12.065
164-05500	0.492/12.497
164-05606	0.395/10.033
164-05700	0.525/13.335
164-05806	0.395/10.033
164-06106	0.475/12.065
164-06306	0.465/11.811
164-06406	0.465/11.811
164-06506	0.240/6.096

Part Number	"A" in/mm
164-06700	0.220/5.588
164-06900	0.205/5.207
164-07200	0.492/12.497
164-07306	0.395/10.033
164-07400	0.492/12.497
164-07500	0.205/5.207
164-07700	0.470/11.938
164-07800	0.450/11.43
164-07906	0.465/11.811
164-08100	0.450/11.43
164-08200	0.327/8.306
164-08300	0.327/8.306
164-08406	0.330/8.382
164-08500	0.325/8.255
164-08800	0.190/4.826
164-08900	0.330/8.382
164-09000	0.330/8.382
164-09100	0.492/12.497
164-09200	0.190/4.826
164-09300	0.190/4.826
164-09400	0.190/4.826
164-09500	0.325/8.255
164-09600	0.325/8.255
164-09700	0.325/8.255
164-09900	0.275/6.985
164-10500	0.157/3.988
164-10700	0.345/8.763
164-10900	0.227/5.766
164-11501	0.327/8.306
164-11700	0.164/4.166
164-11800	0.162/4.115
164-11900	0.227/5.766
164-12000	0.205/5.207
164-12300	0.345/8.763
164-12501	0.445/11.303
164-12502	0.445/11.303
164-12504	0.445/11.303
164-12505	0.445/11.303
164-12601	0.205/5.207
164-13300	0.235/5.969
164-13600	0.327/8.306
164-13601	0.327/8.306
164-14000	0.205/5.207
164-14300	0.205/5.207
164-14800	0.327/8.306
164-16700	0.220/5.588
164-17500	0.205/5.207
164-18300	0.327/8.306
164-18800	0.190/4.826
164-18900	0.330/8.382
164-19000	0.330/8.382
164-19200	0.191/4.826
164-19300	0.190/4.826
164-19400	0.190/4.826
164-19500	0.325/8.255
164-19600	0.325/8.255
164-19700	0.325/8.255

Part Number	"A" in/mm
164-20100	0.250/6.350
164-20206	0.334/8.484
164-20306	0.465/11.811
164-20500	0.525/13.335
164-20600	0.455/11.557
164-20700	0.410/10.414
164-20806	0.475/12.065
164-20900	0.410/10.414
164-21000	0.436/11.074
164-21100	0.492/12.497
164-21200	0.327/8.306
164-21406	0.334/8.484
164-21600	0.405/10.287
164-21700	0.475/12.065
164-21900	0.590/14.986
164-22000	0.360/9.144
164-22201	0.537/13.640
164-22202	0.537/13.640
164-22400	0.385/9.779
164-22900	0.410/10.414
164-23000	0.565/14.351
164-23001	0.582/14.783
164-23002	0.582/14.783
164-23100	0.345/8.763
164-23300	0.475/12.065
164-23400	0.205/5.207
164-23600	0.190/4.826
164-23900	0.325/8.255
164-24000	0.325/8.255
164-24100	0.325/8.255
164-24200	0.167/4.242
164-24400	0.290/7.366
164-24500	0.327/8.306
164-24501	0.327/8.306
164-30007	0.190/4.826
164-30195	0.190/4.826
164-30388	0.325/8.255
164-30398	0.325/8.255
164-30414	0.325/8.255
164-30440	0.190/4.826
164-30615-1	0.190/4.826
164-30615-2	0.330/8.382
164-30615-3	0.330/8.382
164-30804-1	0.190/4.826
164-30804-2	0.330/8.382
164-30804-3	0.330/8.382
464-11501	0.327/8.306
464-11700	0.164/4.166
464-12000	0.205/5.207
464-12601	0.205/5.207
464-13601	0.327/8.306
464-14000	0.205/5.207
464-14300	0.205/5.207
464-17500	0.205/5.207
464-18300	0.327/8.306

## D. Chrome/Performance Gold Disc Maintenance

The primary purpose of chrome plated and performance gold discs is to retard corrosion on the disc flange (rubbing surface) which, if pitted, will wear out linings rapidly. Chrome is a porous material. Performance Gold is also porous but to a much lesser degree than the chrome. Both will allow moisture to penetrate and discolor, giving the appearance of corrosion. To restore the original luster of the cup surface, polish with common automotive chrome polish and a non-metallic abrasive pad (such as 3M Scotch Brite®) – DO NOT USE steel wool. The main area of concern should be the disc flange. As long as it is clean and corrosion-free, the disc will provide the service life designed into it.

The plating will increase the life of a standard disc. When the plating wears off, which it eventually will, you then have a standard disc to wear down to the minimum thickness. The added benefit is the plating will be intact on the non-rubbing surfaces as opposed to the paint on a standard disc.

## E. Assembly/Lining Cross-Reference

This cross-reference identifies the proper brake lining for each of the brake assemblies listed. All linings require conditioning prior to use.

Abbreviations:

Pp = Pressure Plate

Tp = Torque Plate

N/A = Not Available

Bp = Back Plate

Cp = Carrier Plate

Brake Assembly	Lining	Qty
35-200A (30-1)	066-11100	2
C2000 (30-2)	066-00504	2
C7000 (30-3)	066-00504	2
C7000A (30-3A)	066-00504	2
30-4	066-11100	2
30-5	N/A	
30-6	066-11100	2
30-7	066-11100	2
37-200-2 (30-8)	066-10600	8
30-9	066-10600	2
30-9A	066-10600	2
30-9C	066-10600	2
30-9D	066-10600	2
30-9E	066-10600	2
3000-250 (30-12)	066-10600	2
3000-500 (30-13)	066-10600	2
30-18	066-10600	2
30-19	066-10600	2
30-19A	066-10600	2
30-21	066-10600	4
30-23	066-06500 Pp	2
	066-06200 Bp	2

Brake Assembly	Lining	Qty
30-23A	066-06500 Pp	2
	066-06200 Bp	2
30-23B	066-06500 Pp	2
	066-06200 Bp	2
30-23C	066-06500 Pp	2
	066-06200 Bp	2
30-23D	066-06500 Pp	2
	066-06200 Bp	2
30-24	066-10600	4
30-28B	066-03300	6
30-28C	066-03300	6
30-28D	066-03300	6
30-30	066-10500	2
30-31	066-11700 Tp	4
	066-11900 Cp	4
	066-11800 Bp	4
30-32	N/A	
30-32A	066-10600	4
30-32B	066-10600	4
30-32C	066-10600	4
30-32D	066-10600	4
30-32E	066-10600	4

# E. Assembly/Lining Cross-Reference

Brake Assembly	Lining	Qty
30-35	066-10600	4
30-40	066-10600	2
30-40A	066-10600	2
30-41	066-10600	4
30-41A	066-10600	4
30-41B	066-10600	4
30-45	066-11100	2
30-51	066-10600	4
30-51A	066-10600	4
30-51B	066-10600	4
30-52	066-10500	4
30-52A	066-10500	4
30-52B	066-10500	4
30-52D	066-10500	4
30-52E	066-10500	4
30-52F	066-10500	4
30-52G	066-10500	4
30-52H	066-10500	4
30-52K	066-10500	4
30-52L	066-10500	4
30-52M	066-10500	4
30-52N	066-10500	4
30-52P	066-10500	4
30-52Q	066-10500	4
30-52S	066-10500	4
30-52T	066-10500	4
30-52U	066-10500	4
30-52V	066-10500	4
30-52W	066-10500	4
30-52X	066-10500	4
30-52Y	066-10500	4
30-52Z	066-10500	4
30-52AA	066-10500	4
30-52AB	066-10500	4
30-52AC	066-10500	4
30-53	066-11200	2
30-53A	066-11200	2
30-54	066-10500	4
30-54A	066-10500	4
30-54B	066-10500	4
30-54C	066-10500	4
30-55	066-10500	2
30-55B	066-10500	2
30-56	066-10500	2
30-56A	066-10500	2
30-56B	066-10500	2
30-56C	066-10500	2
30-56D	066-10500	2
30-56F	066-10500	2
30-58A	N/A	
30-58B	N/A	
30-59	066-11200	2
30-59A	066-11200	2
30-59D	066-11200	2
30-59E	066-11200	2
30-60	066-10600	4
30-60A	066-10600	4
30-60B	066-10600	4

Brake Assembly	Lining	Qty
30-61	066-10500	4
30-61A	066-03600	4
30-61B	066-03600	4
30-61D	066-10500	4
30-61E	066-10500	4
30-61F	066-10500	4
30-63	066-10500	2
30-63A	066-10500	2
30-63B	066-10500	2
30-63D	066-10500	2
30-63E	066-10500	2
30-63F	066-10500	2
30-63J	066-10500	2
30-63K	066-10500	2
30-63M	066-10500	2
30-63P	066-10500	2
30-63Q	066-10500	2
30-63S	066-10500	2
30-65	066-10500	4
30-65A	066-10500	4
30-65E	066-10500	4
30-66	066-04400	4
30-66A	066-11000	4
30-66B	066-11000	4
30-66C	066-02200	4
30-66D	066-02200	4
30-66F	066-04400	4
30-66G	066-09700	4
30-66H	066-02200	4
30-67	066-10800	4
30-67A	066-10800	4
30-67B	066-10800	4
30-67C	066-10800	4
30-67D	066-10800	4
30-67E	066-10800	8
30-67X	066-10800	4
30-68	066-03300	6
30-68A	066-03300	6
30-68B	066-03300	6
30-69A	066-02200	4
30-69B	066-02200	4
37-200A (30-72)	066-06500 Pp	4
	066-06200 Bp	4
30-74B	066-06700	4
30-75	066-10500	2
30-75A	066-10500	2
30-75B	066-10500	2
30-75X	066-10500	2
30-79	066-10500	2
30-79A	066-10500	2
30-79B	066-10500	2
30-83	066-06200	4
30-83A	066-06200	4
30-84	066-10800	8
30-88	066-02200	8
30-89	066-10800	6
30-89A	066-10800	6
30-89B	066-10800	6

# E. Assembly/Lining Cross-Reference

Brake Assembly	Lining	Qty
30-89C	066-10800	6
30-89E	066-10800	6
30-91	066-11300	12
30-93	066-04400	6
30-93A	066-02200	6
30-93B	066-04400	6
30-93C	066-09700	6
30-93D	066-04400	6
30-93E	066-04400	6
30-94	066-10800	8
30-95	066-03300	8
30-95A	066-06600	8
30-95B	066-06600	8
30-96	066-06200	8
30-97	066-06400	8
30-98	066-10800	12
30-98A	066-10800	12
30-98B	066-10800	12
30-98C	066-10800	12
30-98D	066-10800	12
30-99	066-06600	8
30-99A	066-06600	8
30-100	066-06600	8
30-103	066-11300	16
30-106	066-06800	16
30-107	066-09000	8
30-107A	066-09000	8
30-107B	066-09000	8
30-107C	066-09000	8
30-107D	066-09000	8
30-107E	066-09000	8
30-111	066-10800	8
30-113	066-06400	8
30-113A	066-06400	8
30-123	066-06800	12
30-127	066-06200	4
30-127A	066-06200	4
30-127C	066-06200	4
30-127D	066-06200	4
30-129	066-06200	4
30-131	066-09000	8
30-133	066-10500	2
30-138	066-06800	6
30-139	066-06200	8
30-141	066-07300	8
30-142	066-07300	8
30-143	066-07300	8
30-144	066-09000	8
30-144A	066-09000	8
30-144B	066-09000	8
30-145	066-09700	6
30-146	066-09100 Pp	2
	066-09200 Bp	2
30-146A	066-09100 Pp	2
	066-09200 Bp	2
30-148	066-11300	16
30-149	066-06600	12

Brake Assembly	Lining	Qty
30-158	066-06800	8
30-159	066-09000	8
30-159A	066-09000	8
30-159B	066-09000	8
30-159C	066-09000	8
30-163	066-03300	8
30-164	066-06200	2
30-170	066-10000	8
30-176	066-10800	4
30-181A	066-10600	2
30-182	066-03300	8
30-184	066-10800	8
30-195	066-10800	4
30-195A	066-10800	4
30-208	N/A	
30-208A	066-12901	2
30-210	066-13100	16
30-210A	066-13100	16
30-214	066-10500	2
30-214B	066-10500	2
30-220	066-13500 Pp	2
	066-13700 Bp	2
30-224	066-10500	2
30-231	066-06600	12
30-233	066-06200	4
30-233A	066-06200	4
30-233B	066-06200	4
30-236	066-10500	2
30-239	066-14100	2
30-239A	066-14100	2
30-239B	066-14100	2
30-241	066-10500	4
C-30018	066-30026	2
C-30018-1	066-30026	2
C-30018-2	066-30026	2
C-30018-3	066-30026	2
C-30018-4	066-30026	2
C-30018-5	066-30026	2
C-30018-6	066-30026	2
C-30018-7	066-30026	2
D-30118-3	066-30026	4
D-30118-4	066-30026	4
D-30118-5	066-30026	4
D-30118-6	066-30026	4
D-30118-7	066-30026	4
D-30118-8	066-30026	4
D-30118-9	066-30026	4
D-30118-10	066-30026	4
C-30764-5	066-30026	2
C-30764-6	066-30026	2
C-30764-7	066-30026	2
D-30793-3	066-30026	4
D-30793-4	066-30026	4
D-30793-5	066-30026	4
D-30793-6	066-30026	4

## F. Wheel Assembly Torque Values

### Torque Values

**CAUTION: DO NOT “LUBTORK” ANY BOLT AND NUT COMBINATIONS THAT ARE SPECIFIED AS A “DRY” TORQUE VALUE. IF THERE IS ANY CONFLICT OR QUESTION REGARDING DRY TORQUE, LUBTORK OR TORQUE VALUE ON YOUR ASSEMBLY, PLEASE CONTACT CLEVELAND CUSTOMER SUPPORT FOR RESOLUTION.**

All wheel assembly tie bolt and nut torque values listed are to be applied to the nut only. A “D” shown adjacent to the torque value indicates the value to be a “Dry” torque only. An “L” shown adjacent to the torque value indicates a “Lubtork” torque only. Lubtork requires the application of an antiseize compound to all friction surfaces of the hardware prior to torquing. Only use the antiseize specified for your wheel assembly.

[A5-#] = Code for inflation valve stem torque. See appropriate dash number, -#, in Table G for torque value.

### Bearing Grease

**CAUTION: DO NOT MIX AVIATION WHEEL BEARING GREASES WITH EACH OTHER. IF USING OTHER APPROVED GREASE, COMPLETE REMOVAL OF CONTAINED GREASE AND BEARING CLEANING IS REQUIRED. REPLACEMENT OF PREVIOUSLY LUBRICATED FELT SEALS IS ALSO REQUIRED.**

Included in this section is wheel bearing grease information. Beginning March, 2007 all active wheel assemblies listed in the torque values table, except those noted for amphibious application, will be shipped from the Cleveland Wheels & Brakes facility with the bearings packed with Mobil Aviation Grease SHC 100, the approved preferred grease for all Parker Hannifin wheel assemblies.

If your non-amphibious wheel assembly was shipped prior to March 2007 it may contain other approved bearing grease. To change to the Mobil Aviation Grease SHC 100, you must completely remove the contained grease and clean the bearings. You must also replace any felt grease seals which were previously lubricated with other approved grease.

Refer to Cleveland Wheels & Brakes Component Maintenance Manual, AWBCMM0001, latest issue for additional information and grease packing instructions.

# F. Wheel Assembly Torque Values

## Table Flag Note Legend:

### Material Column Designations:

“A” Aluminum      “M” Magnesium

(1) For assistance contact the Technical Services Hotline (page i).

### Antiseize Compound:

(2) Use SAE AMS2518 (MIL-T-5544).

(3) Use MIL-PRF-83482 (MIL-T-83483).

### Wheel Bearing Grease:

All active wheel assemblies listed are shipped with Mobil Aviation Grease SHC 100 except:

(4) Wheel uses BG Products HCF Grease P/N 605 (Amphibious).

### Torque Values:

(5) Dry torque brake disc bolts to 80 in-lbs.

(6) Dry torque brake disc bolts to 150 in-lbs.

(7) Torque value is dependent on hardware configuration. Refer to PRM 83 for torque values.

(8) Torque value is dependent on hardware configuration. PRM's are in development to release the hardware upgrade for the following assemblies. In the interim, follow the wheel assembly nameplate for torque value. The table below is for reference only. For assistance contact the Technical Services Hotline (Page i).

(9) Torque value is dependent on hardware configuration. Refer to PRM 86 for torque values.

Wheel Assembly	Nut / Washer (qty)	Torque in-lb (N-M)
40-77A, 40-77B, 40-77F, 40-87C, 40-110, 40-168	094-01200 / 095-10400	75 D (8.5)
	094-10300 / 095-10200	90 D (10.2)
40-87	094-01200 / 095-10400 (6)	75 D (8.5)
	094-10300 / 095-10400 (3)	90 D (10.2)
40-78, 40-78A, 40-78B, 40-78E, 40-78J, 40-151, 40-151A, 40-230	094-01200 / 095-10200	75 D (8.5)
	094-10300 / 095-10200	90 D (10.2)
40-87A, 40-87D, 40-87F, 40-110B, 40-152	094-01200 / 095-10400	75 D (8.5)
	094-10300 / 094-10400	90 D (10.2)

# F. Wheel Assembly Torque Values

Wheel Assembly	Bolt Torque		Wheel Mat
	in-lb	N•m	
27-100D (40-1)	90 D	10.2	A
21-100D (40-2)	90 D	10.2	M
3080A (40-3)	90 D	10.2	M
3080B (40-4)	90 D	10.2	M
3070 (40-5)	90 D	10.2	M
3040 (40-6)	90 D	10.2	A
3050 (40-7)	90 D	10.2	A
3050A (40-7A)	90 D	10.2	A
38501 (40-8)	90 D	10.2	M
40-12	90 D	10.2	M
40-12A	90 D	10.2	M
40-18	90 D	10.2	M
40-19	90 D	10.2	A
40-19A	90 D	10.2	A
40-21	90 D	10.2	A
40-24	90 D	10.2	A
40-28	90 D	10.2	M
40-28D	90 D	10.2	M
40-30A	90 D	10.2	A
40-32	90 D	10.2	A
40-34	90 D	10.2	M
40-37	90 D	10.2	A
40-40A	135-145 D	15.3-16.4	M
40-40B	135-145 D	15.3-16.4	M
40-40C	90 D	10.2	M
40-40D	150 D	16.9	M
40-41	150 D	16.9	M
40-46	90 D	10.2	A
40-47	150 D	16.9	A
40-50	90 D	10.2	A
40-55	90 D	10.2	A
40-56	150 D	16.9	M
40-56B	150 D	16.9	M
40-56C	150 D	16.9	M
40-57	90 D	10.2	A
40-57A	90 D	10.2	A
40-58	90 D	10.2	M
40-59	150 D	16.9	M
40-59A	150 D	16.9	M
40-59D	150 D	16.9	M
40-59E	150 D	16.9	M
40-60	90 D	10.2	M
40-60A	90 D	10.2	A
40-61	90 D	10.2	M
40-66	90 D	10.2	A
40-67	90 D	10.2	A
40-74	90 D	10.2	A
40-74A	90 D	10.2	A
40-74B	90 D	10.2	A
40-75B	150 D	16.9	M
40-75D	150 D	16.9	M
40-75E	150 D	16.9	M
40-75F	150 D	16.9	M
40-75G	150 D	16.9	M
40-75H	150 D	16.9	M

Wheel Assembly	Bolt Torque		Wheel Mat
	in-lb	N•m	
40-75J	150 D	16.9	M
40-75P	150 D	16.9	M
40-75S	150 D	16.9	M
40-75T	150 D	16.9	M
40-75W	150 D	16.9	M
40-75Z	150 D	16.9	M
40-76A	150 D	16.9	M
40-76B	150 D	16.9	M
40-76C	150 D	16.9	M
40-76D	150 D	16.9	M
40-76E	150 D	16.9	M
40-76F	150 D	16.9	M
40-76G	150 D	16.9	M
40-76H	150 D	16.9	M
40-76P	150 D	16.9	M
40-76-1	150 D	16.9	(1)
40-77		(9)	M
40-77A		(8)	M
40-77B		(8)	M
40-77C		(7)	M
40-77D	90 D	10.2	M
40-77E		(7)	M
40-77F		(8)	M
40-77G	90 L (2)	10.2	M
40-78		(8)	M
40-78A		(8)	A
40-78B		(8)	M
40-78E		(8)	M
40-78J		(8)	A
40-79	150 D	16.9	M
40-83	150 D	16.9	M
40-83A	150 D	16.9	M
40-83B	150 D	16.9	M
40-84	150 D	16.9	M
40-84A	150 D	16.9	M
40-84B	150 D	16.9	M
40-86	150 D	16.9	M
40-86A	150 D	16.9	M
40-86B	150 D	16.9	M
40-86E	150 D	16.9	M
40-86F	150 D	16.9	M
40-87		(8)	M
40-87A		(8)	M
40-87C		(8)	A
40-87D		(8)	M
40-87F		(8)	M
40-87G	115-135 D	13.0-15.3	M
40-88C	150 D	16.9	M
40-90	150 D	16.9	M
40-90A	150 D	16.9	M
40-90B	150 D	16.9	M
40-90D	150 D	16.9	M
40-90E	150 D	16.9	M
40-90F	150 D	16.9	M
40-96E	150 D	16.9	M

# F. Wheel Assembly Torque Values

Wheel Assembly	Bolt Torque		Wheel Mat
	in-lb	N•m	
40-97A	150 D	16.9	M
40-97B	150 D	16.9	M
40-97C	150 D	16.9	M
40-97D	150 D	16.9	M
40-97E	150 D	16.9	M
40-97F	150 D	16.9	M
40-98	150 D	16.9	M
40-98A	150 D	16.9	M
40-98D	150 D	16.9	M
40-98E	150 D	16.9	M
40-98F	150 D	16.9	M
40-98G	150 D	16.9	M
40-98H	150 D	16.9	M
40-98N	150 D	16.9	M
40-98P	150 D	16.9	M
40-99	90 D	10.2	M
40-101	90 D	10.2	A
40-101A	90 D	10.2	A
40-101D	90 D	10.2	A
40-101E	90 D	10.2	A
40-102	90 D	10.2	M
40-102A	90 D	10.2	M
40-103	90 D	10.2	A
40-103A	90 D	10.2	A
40-106	150 D	16.9	M
40-106A	150 D	16.9	M
40-107A [A5-3]	300 L (2)	33.9	M
40-110		(8)	M
40-110B		(8)	M
40-111	150 D	16.9	M
40-111A	150 D	16.9	M
40-112	90 D	10.2	A
40-113	90 D	10.2	A
40-113A	90 D	10.2	A
40-113B	90 D	10.2	A
40-113C	90 D	10.2	A
40-113X	90 D	10.2	A
40-115	90 D	10.2	M
40-115A	115-135 D	13.0-15.3	M
40-115B	115-135 D	13.0-15.3	M
40-115C	115-135 D	13.0-15.3	M
3080D (40-116) (5)	90 D	10.2	M
40-117A	150 D	16.9	M
40-120	150 D	16.9	M
40-120A	150 D	16.9	M
40-120C	150 D	16.9	M
40-124	180 D	20.3	M
40-127	180 L (2)	20.3	A
40-128	180 D	20.3	M
40-128A	180 D	20.3	M
40-128C	180 D	20.3	M
40-128D	180 D	20.3	M
40-128E	180 D	20.3	M
40-129	90 D	10.2	A

Wheel Assembly	Bolt Torque		Wheel Mat
	in-lb	N•m	
40-130	90 D	10.2	M
40-131 (5)	90 D	10.2	M
40-132 [A5-1]	150 D	16.9	M
40-133	150 D	16.9	A
40-134 [A5-2]	150 D	16.9	M
40-134A [A5-2]	150 D	16.9	M
40-135	135-145 D	15.3-16.4	M
40-135A	150 D	16.9	M
40-137	180 D	20.3	A
40-138A	150 D	16.9	M
40-139	150 D	16.9	A
40-140	150 D	16.9	M
40-140A	150 D	16.9	M
40-140B	150 D	16.9	M
40-140C	150 D	16.9	M
40-141	150 D	16.9	M
40-142	150 D	16.9	M
40-142A	150 D	16.9	M
40-143	150 D	16.9	M
40-148 [A5-3]	300 D	33.9	M
40-151		(8)	M
40-151A		(8)	A
40-152		(8)	M
40-162	150 D	16.9	M
40-163	150 D	16.9	M
40-166 [A5-1] (6)	300 D	33.9	M
40-167 (6)	300 D	33.9	M
40-168		(8)	A
40-169 [A5-1] (6)	150 D	16.9	M
40-170 [A5-3]	300 L (2)	33.9	M
40-170A [A5-3]	300 L (2)	33.9	A
40-170B [A5-3]	300 L (2)	33.9	M
40-171	180 D	20.3	M
40-172	180 D	20.3	M
40-174	300 L (2)	33.9	A
40-175	150 D	16.9	A
40-176 [A5-1]	300 D	33.9	A
40-176A [A5-1]	300 D	33.9	A
40-177A	150 D	16.9	M
40-179	150 D	16.9	A
40-179A	150 D	16.9	A
40-181B [A5-1]	180 D	20.3	A
40-181C [A5-1]	180 D	20.3	A
40-193	150 D	16.9	A
40-195	150 D	16.9	M
40-196	90 D	10.2	A
40-198 [A5-3]	300 L (2)	33.9	A
40-199	90 D	10.2	A
40-199A	90 D	10.2	A
40-202 [A5-1]	300 L (1)	33.9	A
40-203 [A5-4]	290-300 L (2)	32.8-33.9	A
40-204 [A5-4]	290-300 L (2)	32.8-33.9	A
40-205 [A5-1]	180 D	20.3	M
40-210 [A5-6]	150 L (2)	16.9	M



# F. Wheel Assembly Torque Values

Wheel Assembly	Bolt Torque		Wheel Mat	Wheel Assembly	Bolt Torque		Wheel Mat
	in-lb	Nm			in-lb	Nm	
40-211 [A5-3]	300 D	33.9	M	40-426A (4)	150 D	16.9	A
040-21101 [A5-3]	300 L (2)	33.9	M	40-434 [A5-6]	315-325 L (3)	35.6-36.7	A
40-212 [A5-1]	150 L (2)	16.9	M	40-450	105-115 L (2)	11.9-13.0	A
40-223	90 D	10.2	A	40-455	150 D	16.9	A
40-230	(8)		M	C-30174-1	95 D	10.7	(1)
40-234	90 D	10.2	A	C-30179	95 D	10.7	(1)
40-239 [A5-6]	300 L (2)	33.9	A	D-30204	95 D	10.7	(1)
040-23901 [A5-6]	300 L (2)	33.9	A	D-30255	195 D	22.0	(1)
40-240A [A5-6]	125 L (2)	14.1	M	D-30260	195 D	22.0	(1)
40-255 [A5-1]	90-100 L (2)	10.2-11.3	M	D-30260-1	195 D	22.0	(1)
40-256	135-145 D	15.3-16.4	M	D-30291-1	195 D	22.0	A
40-258	300 D	33.9	(1)	D-30291-2	195 D	22.0	A
40-259 [A5-1]	95-105 L (2)	10.7-11.8	M	D-30291-3	195 D	22.0	A
40-260 [A5-1]	95-105 L (2)	10.7-11.8	M	D-30291-4	195 D	22.0	A
40-262A [A5-6]	90 L (2)	10.2	M	D-30291-5	195 D	22.0	A
40-270 [A5-6]	115-135 L (2)	13.0-15.3	M	D-30291-6	195 D	22.0	A
40-273 [A5-5]	300 L (2)	33.9	A	D-30380	95 D	10.7	A
40-273A [A5-4]	290-300 L (2)	32.8-33.9	A	C-30480	195 D	22.0	(1)
40-273B [A5-4]	290-300 L (2)	32.8-33.9	A	D-30500	145 D	16.4	A
40-276 [A5-6]	90-100 L (2)	10.2-11.3	M	D-30500-1	145 D	16.4	A
40-279 [A5-3]	300 L (2)	33.9	M	D-30570	195 D	22.0	A
40-279A	300 L (3)	33.9	M	D-30580	195 D	22.0	(1)
40-281	90 D	10.2	M	D-30585	195 D	22.0	(1)
40-289 [A5-1]	300 L (2)	33.9	M	D-30660-1	145 D	16.4	A
40-293 [A5-6]	180-190 L (2)	20.3-21.5	M	D-30660-2	145 D	16.4	A
40-403	150 D	16.9	A	D-30660-3	145 D	16.4	A
40-406	150 D	16.9	M	D-30660-4	145 D	16.4	A
40-406A	150 D	16.9	M	D-30660-5	145 D	16.4	A
40-407	150 D	16.9	M	D-30660-6	145 D	16.4	A
40-414	150 D	16.9	M	D-30660-7	145 D	16.4	A
40-414A	150 D	16.9	M	D-30660-8	145 D	16.4	A
40-417 [A5-7]	115-125 L (3)	13.0-14.1	A	D-30660-9	145 D	16.4	A
40-418 (4)	150 D	16.9	A	D-30660-10	145 D	16.4	A
40-418A (4)	150 D	16.9	A	D-30665	145 D	16.4	A
40-418B (4)	150 D	16.9	A	D-30665-1	145 D	16.4	A
40-426 (4)	150 D	16.9	A				

# G. Tire Inflation Valve Stem Torque

Dash No.	Inflation Valve P/N	Recommended Torque	
		in-lb	Nm
A5-1	160-00700	50-60	5.7-6.8
A5-2	160-00900	165-200	18.7-22.6
A5-3	160-01100	75-100	8.4-11.3
A5-4	160-01200	35-45	4.0-5.1
A5-5	160-01500	70-80	7.9-9.0
A5-6	160-01900	50-60	5.7-6.8
A5-7	160-02000	25-35	2.8-4.0

## H. Back Plate Tie Bolt Torque

A “D” shown adjacent to the torque value indicates the value to be a “Dry” torque only. An “L” shown adjacent to the torque value indicates a “Lubtork” torque only. Lubtork requires the application of an antiseize compound to all friction surfaces of the hardware prior to torquing. Only use the antiseize specified for your brake assembly. A flag note will specify which antiseize to use. Overtorquing (exceeding these values) could cause depressions in the brake cylinder, which result in dragging or bound up brakes. Use a torque wrench when installing back plate bolts to ensure the proper torquing values are attained. Replace the back plate tie bolts with approved bolts as shown in the Cleveland Product Catalog. Depressions in the brake cylinder (surface A) exceeding 0.005 inch (0.127 mm) deep require replacement of the brake cylinder.

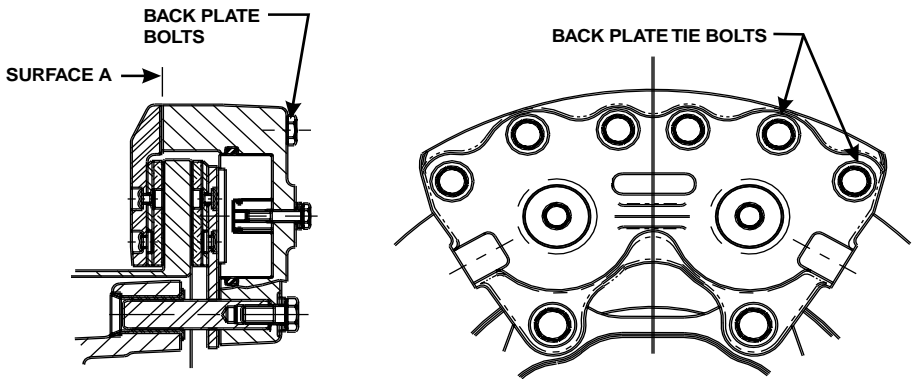

Figure A3 – Back Plate Tie Bolts

### Table Flag Note Legend:

#### Material Column Designations:

“**A**” Aluminum “**M**” Magnesium “**S**” Steel

(1) For assistance contact the Technical Services Hotline (page i).

#### Antiseize Compound:

(2) Use SAE AMS2518 (MIL-T-5544).

(3) Use MIL-PRF-83483 (MIL-T-83483).

# H. Back Plate Tie Bolt Torque

Brake Assembly	Bolt Torque		Matl		
	in-lb	N•m	Housing	Torque Plate	
35-200A (30-1)	60 D	6.8	A	S	
30-4	60 D	6.8	A	S	
30-5	60 D	6.8	A	S	
30-6	60 D	6.8	A	S	
30-7	60 D	6.8	A	S	
30-4	60 D	6.8	A	S	
37-200-2 (30-8)	90 D	10.2	A	S	
30-9	75-80 D	8.5-9.0	A	S	
30-9A	75-80 D	8.5-9.0	A	S	
30-9C	75-80 D	8.5-9.0	A	S	
30-9D	75-80 D	8.5-9.0	A	S	
30-9E	75-80 D	8.5-9.0	A	S	
3000-250 (30-12)	90 D	10.2	A	S	
3000-500 (30-13)	90 D	10.2	A	S	
30-18	75-80 D	8.5-9.0	A	S	
30-19	75-80 D	8.5-9.0	A	S	
30-19A	75-80 D	8.5-9.0	A	S	
30-21	65-75 D	7.3-8.5	A	S	
30-23	65-75 D	7.3-8.5	A	N/A	
30-23A	65-75 D	7.3-8.5	A	N/A	
30-23B	65-75 D	7.3-8.5	A	N/A	
30-23C	65-75 D	7.3-8.5	A	N/A	
30-23D	65-75 D	7.3-8.5	A	N/A	
30-24	65-75 D	7.3-8.5	(1)	(1)	
30-28B	80-90 D	9.0-10.2	M	M	
30-28C	80-90 D	9.0-10.2	M	M	
30-28D	80-90 D	9.0-10.2	M	M	
30-30	90 D	10.2	M	S	
30-31	1/4-28 85-90 D	9.6-10.2	A	S	
	3/8-24 125-150 D				14.0-17.0
30-32	65-75 D	7.3-8.5	A	S	
30-32A	65-75 D	7.3-8.5	A	S	
30-32B	65-75 D	7.3-8.5	A	S	
30-32C	65-75 D	7.3-8.5	A	S	
30-32E	65-75 D	7.3-8.5	A	S	
30-35	65-75 D	7.3-8.5	(1)	S	
30-40	60 D	6.8	A	S	
30-40A	75-80 D	8.5-9.0	A	S	
30-41	65-75 D	7.3-8.5	A	N/A	
30-41A	90 D	10.2	A	S	
30-41B	65-75 D	7.3-8.5	A	N/A	
30-45	60 D	6.8	A	S	

Brake Assembly	Bolt Torque		Matl	
	in-lb	N•m	Housing	Torque Plate
30-51	65-75 D	7.3-8.5	A	S
30-51A	65-75 D	7.3-8.5	A	S
30-51B	65-75 D	7.3-8.5	A	S
30-52	90 D	10.2	M	S
30-52A	90 D	10.2	M	S
30-52B	90 D	10.2	M	S
30-52D	90 D	10.2	M	S
30-52E	90 D	10.2	M	S
30-52F	90 D	10.2	M	S
30-52G	90 D	10.2	M	S
30-52H	90 D	10.2	M	S
30-52K	90 D	10.2	M	S
30-52L	75-80	8.5-9.0	M	N/A
30-52M	90 D	10.2	M	S
30-52N	90 D	10.2	M	S
30-52P	90 D	10.2	M	S
30-52Q	90 D	10.2	M	S
30-52S	90 D	10.2	M	S
30-52T	90 D	10.2	M	S
30-52U	90 D	10.2	M	S
30-52V	90 D	10.2	M	S
30-52W	90 D	10.2	M	S
30-52X	90 D	10.2	M	S
30-52Y	90 D	10.2	M	S
30-52Z	90 D	10.2	M	S
30-52AA	90 D	10.2	M	S
30-52AB	90 D	10.2	M	S
30-52AC	90 D	10.2	M	S
30-53	75-80 D	8.5-9.0	(1)	(1)
30-53A	75-80 D	8.5-9.0	M	S
30-54	90 D	10.2	M	A
30-54A	90 D	10.2	M	A
30-54B	90 D	10.2	M	S
30-54C	85-90 D	9.6-10.2	M	A
30-55	75-80 D	8.5-9.0	M	S
30-55A	75-80 D	8.5-9.0	(1)	(1)
30-55B	75-80 D	8.5-9.0	M	S
30-56	75-80 D	8.5-9.0	M	S
30-56A	75-80 D	8.5-9.0	M	S
30-56B	75-80 D	8.5-9.0	M	S
30-56C	75-80 D	8.5-9.0	M	S
30-56D	75-80 D	8.5-9.0	M	S
30-56F	75-80 D	8.5-9.0	M	S
30-58A	75-80 D	8.5-9.0	(1)	(1)
30-58B	75-80 D	8.5-9.0	M	(1)
30-59	75-80 D	8.5-9.0	M	S
30-59A	75-80 D	8.5-9.0	M	S
30-59E	75-80 D	8.5-9.0	M	S

# H. Back Plate Tie Bolt Torque

Brake Assembly	Bolt Torque		Matl	
	in-lb	N•m	Housing	Torque Plate
30-60	75-80 D	8.5-9.0	(1)	S
30-60A	65-75 D	7.3-8.5	A	S
30-60B	65-75 D	7.3-8.5	A	S
30-61	90 D	10.2	M	S
30-61A	90 D	10.2	M	S
30-61B	65-75 D	7.3-8.5	M	S
30-61D	90 D	10.2	M	S
30-61E	90 D	10.2	M	S
30-61F	90 D	10.2	M	S
30-63	75-80 D	8.5-9.0	M	S
30-63A	75-80 D	8.5-9.0	M	S
30-63B	75-80 D	8.5-9.0	M	S
30-63D	75-80 D	8.5-9.0	M	S
30-63E	75-80 D	8.5-9.0	M	S
30-63F	75-80 D	8.5-9.0	M	S
30-63J	75-80 D	8.5-9.0	M	S
30-63K	75-80 D	8.5-9.0	M	S
30-63M	75-80 D	8.5-9.0	M	S
30-63P	75-80 D	8.5-9.0	M	S
30-63Q	75-80 D	8.5-9.0	M	S
30-63S	75-80 D	8.5-9.0	M	S
30-65	75-90 D	8.5-10.2	M	S
30-65A	75-90 D	8.5-10.2	M	S
30-65E	75-90 D	8.5-10.2	M	S
30-66	90 D	10.2	A	A
30-66A	90 D	10.2	M	M
30-66B	90 D	10.2	A	A
30-66C	90 D	10.2	A	A
30-66D	90 D	10.2	M	(1)
30-66F	90 D	10.2	M	M
30-66G	80-90 D	9.0-10.2	M	A
30-66H	75-90 D	8.5-10.2	M	S
30-67	85-90 D	9.6-10.2	A	A
30-67A	85-90 D	9.6-10.2	A	A
30-67B	85-90 D	9.6-10.2	A	A
30-67C	85-90 D	9.6-10.2	A	A
30-67D	85-90 D	9.6-10.2	A	A
30-67E	85-90 D	9.6-10.2	A	A
30-67X	85-90 D	9.6-10.2	A	A
30-68	75-80 D	8.5-9.0	M	M
30-68A	75-80 D	8.5-9.0	M	M
30-68B	75-80 D	8.5-9.0	M	M
30-69A	85-95 D	9.6-10.7	M	M
30-69B	90 D	10.2	M	M
37-200A (30-72)	65-70 D	7.3-7.9	A	S
30-74B	60-75 D	6.8-8.5	M	M
30-75	75-80 D	8.5-9.0	A	S

Brake Assembly	Bolt Torque		Matl	
	in-lb	N•m	Housing	Torque Plate
30-75A	75-80 D	8.5-9.0	A	S
30-75B	75-80 D	8.5-9.0	A	S
30-75X	75-80 D	8.5-9.0	A	S
30-79	90 D	10.2	A	S
30-79A	90 D	10.2	A	S
30-79B	90 D	10.2	A	S
30-83	90 D	10.2	M	S
30-83A	90 D	10.2	M	S
30-84	80-90 D	9.0-10.2	A	N/A
30-88	75-80 D	8.5-9.0	M	A
30-89	80-90 D	9.0-10.2	A	A
30-89A	80-90 D	9.0-10.2	A	A
30-89B	80-90 D	9.0-10.2	A	A
30-89C	80-90 D	9.0-10.2	A	A
30-89E	80-90 D	9.0-10.2	A	A
30-93	80-90 D	9.0-10.2	M	M
30-93A	80-90 D	9.0-10.2	M	M
30-93B	80-90 D	9.0-10.2	M	M
30-93C	80-90 D	9.0-10.2	M	M
30-93D	80-90 D	9.0-10.2	M	M
30-93E	90-100 D	10.2-11.3	M	M
30-94	80-90 D	9.0-10.2	A	A
30-95	60 D	6.8	(1)	(1)
30-95A	60 D	6.8	M	M
30-95B	60 D	6.8	M	M
30-96	60 D	6.8	M	S
30-97	80-90 D	9.0-10.2	A	M
30-98	80-90 D	9.0-10.2	A	A
30-98A	80-90 D	9.0-10.2	A	A
30-98B	80-90 D	9.0-10.2	A	A
30-98C	80-90 D	9.0-10.2	A	A
30-98D	80-90 D	9.0-10.2	A	A
30-99	75-80 D	8.5-9.0	M	A
30-99A	75-80 D	8.5-9.0	M	M
30-100	75-80 D	8.5-9.0	M	M
30-106	80-90 D	9.0-10.2	M	M
30-107	85-90 D	9.6-10.2	A	M
30-107A	85-90 D	9.6-10.2	A	M
30-107B	85-90 D	9.6-10.2	A	M
30-107C	85-90 D	9.6-10.2	A	M
30-107D	85-90 D	9.6-10.2	A	M
30-107E	80-95 D	9.0-10.7	A	M
30-111	80-90 D	9.0-10.2	A	A
30-113	80-90 D	9.0-10.2	A	M
30-113A	80-90 D	9.0-10.2	A	M
30-123	80-90 D	9.0-10.2	M	M
30-127	90 D	10.2	M	S
30-127A	90 D	10.2	M	S

# H. Back Plate Tie Bolt Torque

Brake Assembly	Bolt Torque		Matl	
	in-lb	N•m	Housing	Torque Plate
30-127C	90 D	10.2	M	S
30-127D	90 D	10.2	M	S
30-129	75-90 D	8.5-10.2	M	S
30-131	80-90 D	9.0-10.2	A	M
30-133	75-80 D	8.5-9.0	M	S
30-138	80-90 D	9.0-10.2	M	M
30-139	75-80 D	8.5-9.0	M	S
30-141	150 D	16.9	A	M
30-142	150 D	16.9	A	M
30-143	150 D	16.9	A	M
30-144	85-90 D	9.6-10.2	A	M
30-144A	85-90 D	9.6-10.2	A	M
30-144B	85-90 D	9.6-10.2	A	M
30-145	80-90 D	9.0-10.2	M	M
30-146	85-90 D	9.6-10.2	A	M
30-146A	85-90 D	9.6-10.2	A	A
30-149	80-90 D	9.0-10.2	A	A
30-158	80-90 D	9.0-10.2	M	M
30-159	85-90 D	9.6-10.2	A	M
30-159A	85-90 D	9.6-10.2	A	M
30-159B	85-90 D	9.6-10.2	A	M
30-159C	85-90 D	9.6-10.2	A	M
30-163	85-90 D	9.6-10.2	M	A
30-164	75-80 D	8.5-9.0	M	S
30-170	80-85 D	9.0-9.6	A	A
30-176	85-90 D	9.6-10.2	A	A
30-181A	75-80 D	8.5-9.0	A	S
30-182	85-90 D	9.6-10.2	M	A
30-184	80-90 D	9.0-10.2	A	A
30-195	85-90 D	9.6-10.2	A	A
30-195A	85-90 D	9.6-10.2	A	A
30-210	80-85 L (2)	9.0-9.6	A	A
30-210A	80-85 L (3)	9.0-9.6	A	A
30-214	75-80 D	8.5-9.0	M	S
30-214B	75-80 D	8.5-9.0	M	S
30-220	85-90 D	9.6-10.2	A	M
30-224	75-80 D	8.5-9.0	M	S
30-231	80-90 D	9.0-10.2	A	A
30-233	90 D	10.2	M	S
30-233A	90 D	10.2	M	S
30-233B	90 D	10.2	M	S
30-236	75-80 D	8.5-9.0	M	N/A
30-239	75-80	8.5-9.0	M	S
30-239A	75-80	8.5-9.0	M	S
30-239B	75-80	8.5-9.0	A	S
30-241	90 L (3)	10.2	A	S
C-30018	120-130 D	13.6-14.7	A	S
C-30018-1	120-130 D	13.6-14.7	A	S

Brake Assembly	Bolt Torque		Matl	
	in-lb	N•m	Housing	Torque Plate
C-30018-2	120-130 D	13.6-14.7	A	S
C-30018-3	120-130 D	13.6-14.7	A	S
C-30018-4	120-130 D	13.6-14.7	A	S
C-30018-5	120-130 D	13.6-14.7	A	S
C-30018-6	120-130 D	13.6-14.7	A	S
C-30018-7	120-130 D	13.6-14.7	A	S
D-30118-3	100-110 D	11.3-12.4	A	S
D-30118-4	100-110 D	11.3-12.4	A	S
D-30118-5	100-110 D	11.3-12.4	A	S
D-30118-6	100-110 D	11.3-12.4	A	S
D-30118-7	100-110 D	11.3-12.4	A	S
D-30118-8	100-110 D	11.3-12.4	A	S
D-30118-9	100-110 D	11.3-12.4	A	S
D-30118-10	100-110 D	11.3-12.4	A	S
C-30764-5	120-130 D	13.6-14.7	A	S
C-30764-6	120-130 D	13.6-14.7	A	S
C-30764-7	120-130 D	13.6-14.7	A	S
D-30793-3	100-110 D	11.3-12.4	A	S
D-30793-4	100-110 D	11.3-12.4	A	S
D-30793-5	100-110 D	11.3-12.4	A	S
D-30793-6	100-110 D	11.3-12.4	A	S

## I. Special Tools

Item	Part No.	Description
Rivet Set Kit	199-1	Consists of Punch & Anvil
Parker O-Ring Extractor Kit	199-18	Consists of Multi-hook, Multi-ramp & Case
Brake Line Bleeder	087-00500	The brake line bleeder can be used to service all Cleveland hydraulic brake assemblies or any other brake assembly utilizing the 079-00300 FC6446) Bleeder Screw.
Brake Lining Rivet Tool Kit	199-579	Consists of a tool frame, anvil, set, punch, and tool bag. It is for use with P/N's 105-00200 (5/32" rivets) and 177-00300 (5/32" pins) on external caliper type brake assemblies.

## J. Elastomeric Compound Lubricants

### Pneumatic Applications

Grease per MIL-G-4343

Royco 43 – Royal Lubricants Co., East Hanover, NJ

Aeroshell 43 – Royal Lubricants Co., Inc., East Hanover, NJ

Cosmolube 615 – Houghton International, Inc., Fogelsville, PA

Other:

55 O-Ring Lubricant - Dow Corning Corp., Midland, MI

### Hydraulic Applications - Use fluids compatible with the system

MIL-H-5606 / MIL-H-83282 (Red Oils)

Skydrol – Only compatible with itself

## K. Lubricants

### Wheel Bearing Grease – Refer to Topic F, Bearing Grease paragraph

MIL-PRF-81322, Grade 2 or DOD-G-24508A

(Aeroshell Grease 22) Shell Oil Company, Metairie, LA

Mobil Aviation Grease SHC 100

ExxonMobil Oil Corp., Beaumont, TX

HCF Grease P/N 605 (Amphibious)

BG Products, Wichita, KS

### Bolts/Nuts Antiseize – Use antiseize specified for your assembly

per SAE-AMS2518 (MIL-T-5544)

Armit Laboratories, Costa Mesa, CA

Royco 44 - Royal Lubricant, East Hanover, NJ

per MIL-PRF-83483

Moly-50 P/N 51094 – Fel-Pro Chemical Products L.P., Skokie, IL

### Pipe Threads - Apply to first 3 threads of brake cylinder inlet fittings

Lubon #404 – Oil Center Research, Lafayette, LA

## L. Repair Materials

**Aluminum** - Conversion Coating per MIL-C-5541, Class 1A, (Alodine)

**Magnesium** - Surface Pretreatment per AMS-M-3171 (MIL-M-3171)  
 Type III (Dip), Type VI (Brush On) or  
 Type VIII (Dip)  
 IRIDITE 15, MacDermid Inc.,  
 Waterbury, CT (800-325-4158)

## M. Primers and Paints

Color	Columbia Paint Corp. (1) Huntington, WV Ph: 304-529-3237	Sherwin Williams Cleveland, OH www.sherwin-williams.com
White Paint	18-017A (Gray Primer)	P60G2 (Primer)
	11-358A (524 Gloss White)	F63W13 (White)
Silver Paint	18-017A (Gray Primer)	P60G2 (Primer)
	17-250A (524 Aluminum)	F63BXS58-4337 (Silver)
Silver Paint (brake discs)	18-017A (Gray Primer) or 12-231A (Dk Gray Primer)	P60G2 (Primer)
	17-250A (524 Aluminum)	F63BXS58-4337 (Silver)

(1) Products are low volatile organic compounds (low VOC) and water reducible. Longer drying times may be required.

ZRC Products (Quincy, MA) phone: 1-800-831-3275

- ZRC Galvilitite Cold Galvanizing Compound  
 (per MIL-P-26915A) – P/N 11011-10014

## N. Chemical Stripping Agents

**For Magnesium alloys AZ81 and AZ**

Turco Products (Carson, CA) [www.hstna.com/turco/aviation.cfm](http://www.hstna.com/turco/aviation.cfm)

- Spray or brush on application:  
 Water Based Environmentally Advantaged Paint Remover  
 P/N T-6813 or T-6840S
- Tank type stripping application:  
 Diphas Hot Tank Paint Remover  
 P/N T-6813 or T-5668

# Cleveland

Wheels & Brakes



---

**Parker Hannifin Corporation • Aircraft Wheel & Brake Division**

1160 Center Road • Avon, Ohio 44011

Web site: [www.clevelandwheelsandbrakes.com](http://www.clevelandwheelsandbrakes.com) or [www.parker.com/ag/wbd](http://www.parker.com/ag/wbd)

E-mail: [techhelp@parker.com](mailto:techhelp@parker.com) • Fax (440) 937-5409

Technical Services Hotline:

1-800-BRAKING (1-800-272-5464) • (440) 937-1315

---

AWBTSG0001-1